



維盟科技有限公司
Ewowave Technology Co., Ltd.

規格書 / Specification

Description:	Linear Vibration Motor
Part No.:	LG103020WXX
Date:	2015/04/22

地址:新北市汐止區康寧街 169 巷 27 號 10 樓之 1

Address: 10F-1, No.27, Lane 169, Kang-ning St., Hsi Chih
221, Taipei, Taiwan.

Tel: 886-2-2692-6058

Fax: 886-2-2692-6659

1. REVISION HISTORY

REV No.	Date	Description	Inspector	Designed	Approved
00	2015.02.02	New	J.J KIM		T.B PARK

Part Number		Company	Evowave	Approval No.	L10304A-0202
Specification	Φ10 x 3.0T	Name of applied Model	LG103020WXX	Enactment	2015.02.02
				Revision	

Scope

This specification is applied to LG103020WXX vibrator for a pager and a mobile telephone.

Contents

Items	Page	Remark
1. Structure and material	3	
2. Rated specification	4	
3. Frequency response characteristics	4	
4. Reliability	5 ~ 6	
5. Standard test conditions	6 ~ 7	
6. Dimensions	8	
7. Packing specification	9	
8. Cautions	10	

1. Structure and material

1.1 structure

Items	Specification
1. Motor structure	Resonant type vibrator
2. Number of phases	1-phase
3. Number of magnet pole	1-poles (Axial type)

1.2 Material

Items	Specification
1. Case, Bracket	SPC
2. Magnet	Nd-Fe-B Magnet
3. Coil	Self-bonded polyurethan copper wire
4. Spring	SUS-301

Part Number		Company	Evowave	Approval No.	L10304A-0202
Specification	Φ10 x 3.0T	Name of applied Model	LG103020WXX	Enactment	2015.02.02
				Revision	

2. Rated specifications

No.	Items	Specification
2-1	Input voltage <small>note.1)</small>	2.0Vrms, sine wave
2-2	Operational frequency	205Hz
2-3	Vibration	1.5 ± 0.3 Grms
2-4	Rated current	80mArms max.
2-5	Terminal resistance	26 ± 3 Ω
2-6	Rising time	50 ms Max.(50% of the steady state)
2-7	Falling time <small>note.2)</small>	80 ms max.(50% of the steady state)
2-8	Acoustic noise	45 dB(A) max.
2-9	Weight of the product	(2.0 ± 0.1) gram
2-10	Allowable temperature range <small>note.3)</small>	1) Working temperature : -20℃ ~ +70℃ 2) Storage temperature : -40℃ ~ +80℃
2-11	Standard test condition	Section. 5.

Note.1) Square wave Input voltage may cause a little difference on the performance.

Note.2) Phase shift circuit or algorithm is needed to decrease the falling time.

Note.3) The allowable temperature range is corresponded to the reliability specifications.

3. Frequency response characteristics

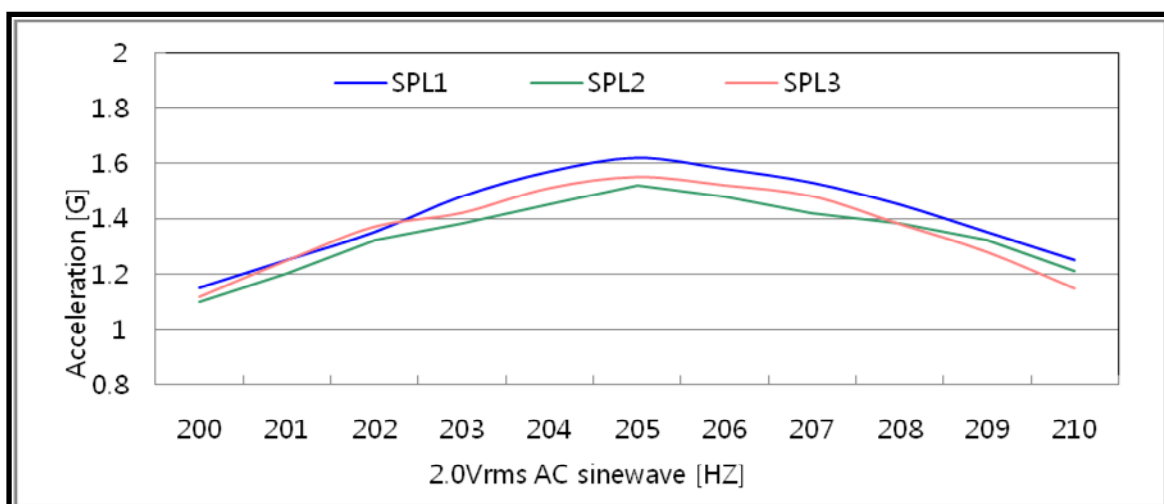

Note) The resonant frequency is normally distributed and controlled so as to be near 205Hz.

Part Number		Company	Evowave	Approval No.	L10304A-0202
Specification	Φ10 x 3.0T	Name of applied Model	LG103020WXX	Enactment	2015.02.02
				Revision	

4. Reliability

After test, the evaluation items of table 1 should be satisfied.

No.	Items	Test condition
4-1	High temperature storage test	Expose to 80 °C for 168hours and then return to normal temperature and humidity for 4hours before test.
4-2	Low temperature storage test	Expose to -40 °C for 168hours and then return to normal temperature and humidity for 4hours before test.
4-3	Humidity test	Expose to 60 °C, 90%RH for 168hours and then return to normal temperature and humidity for 24hours before test.
4-4	Thermal shock test	Confirmed to operating of motor during 10 cycles as following test condition and then return to normal temperature and humidity for 4 hours before test. (Test condition : Refer to note.4)
4-5	Vibration test	Vibrate with 1.5mm, 10~55Hzm, X-Y-Z each direction for 2 hours(total 6 hours) after attachment of 100gf jig.
4-6	Free-drop	Free-drop each side from 1.5m above standard test equipment (18 times) after attachment of 130gf jig.
4-7	Life cycle test	Should be satisfied with the evaluation items of table 1. after 200,000 cycles with the rated operating condition in normal temperature and humidity.(cycle test condition : 2.0 sec. on, 1.0 sec. off)

Note.4) Thermal shock test condition

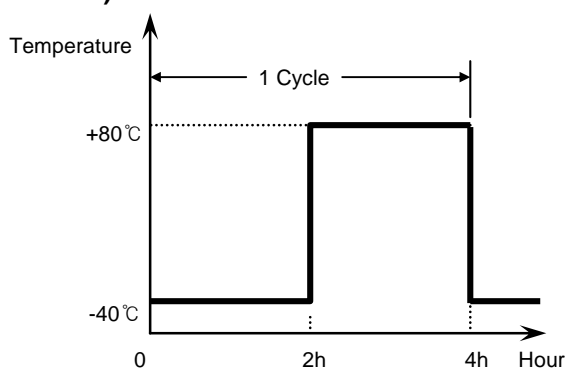

※ A dummy jig for free-drop



mass : 130gr \pm 10%
 Size : 110 X 65 X 16 mm
 Material : POM
 Thickness of the cushion tape : 1.0mm
 (Compressive ratio : 50%)
 The upper case is faced to the cushion tape

Part Number		Company	Evowave	Approval No.	L10304A-0202
Specification	Φ10 x 3.0T	Name of applied Model	LG103020WXX	Enactment	2015.02.02
				Revision	

Table 1. Evaluation items after reliability test

No.	Items	Specification
1-1	Rated current	80mA max.
1-2	Vibration	Shall not exceed $\pm 30\%$ from the initial value
1-3	Rising time	
1-4	Acoustic noise	45dB(A) max.
1-5	Others	No deformation, crack, separation of parts.

5. Standard Test Condition.

■ Measurement of performance

All the performances are measured at normal temperature (25 ± 2 °C) and humidity ($60 \pm 20\%$ RH).

5.1 Vibration

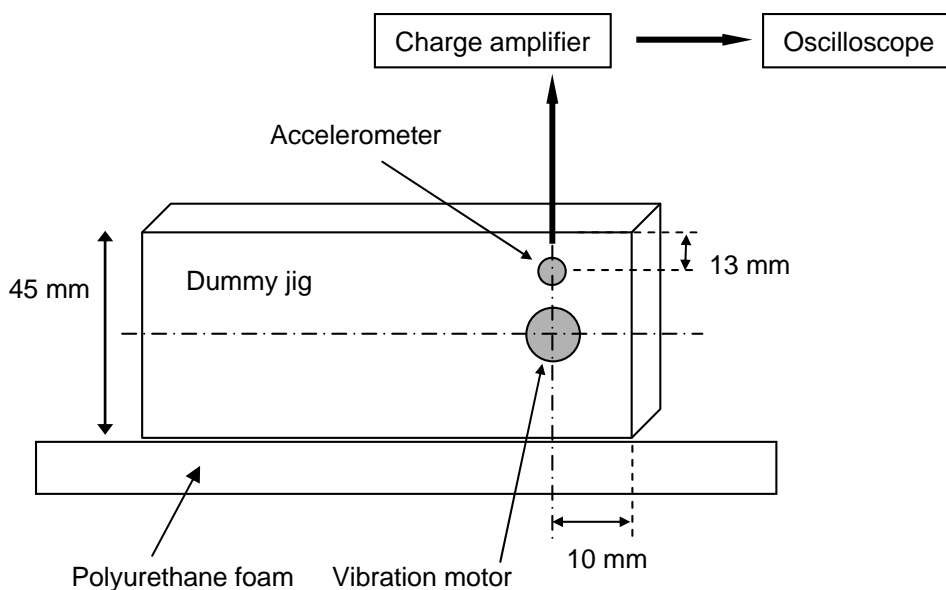

■ Specification of the dummy Jig

- Size : 45mm x 105mm x 15mm
- Weight : 100gr
- Material : Bakelite
- Vibration motor should be attached by using a double-sided tape.

Part Number		Company	Evowave	Approval No.	L10304A-0202
Specification	Φ10 x 3.0T	Name of applied Model	LG103020WXX	Enactment	2015.02.02
				Revision	

5.2 Rise/Falling time

- Rising time : The time when the acceleration reaches 50% of the vibration force(or steady-state) after the power is applied.
- Falling time : The time when the acceleration reaches 10% of the vibration force(or steady-state) after the power is disconnected.

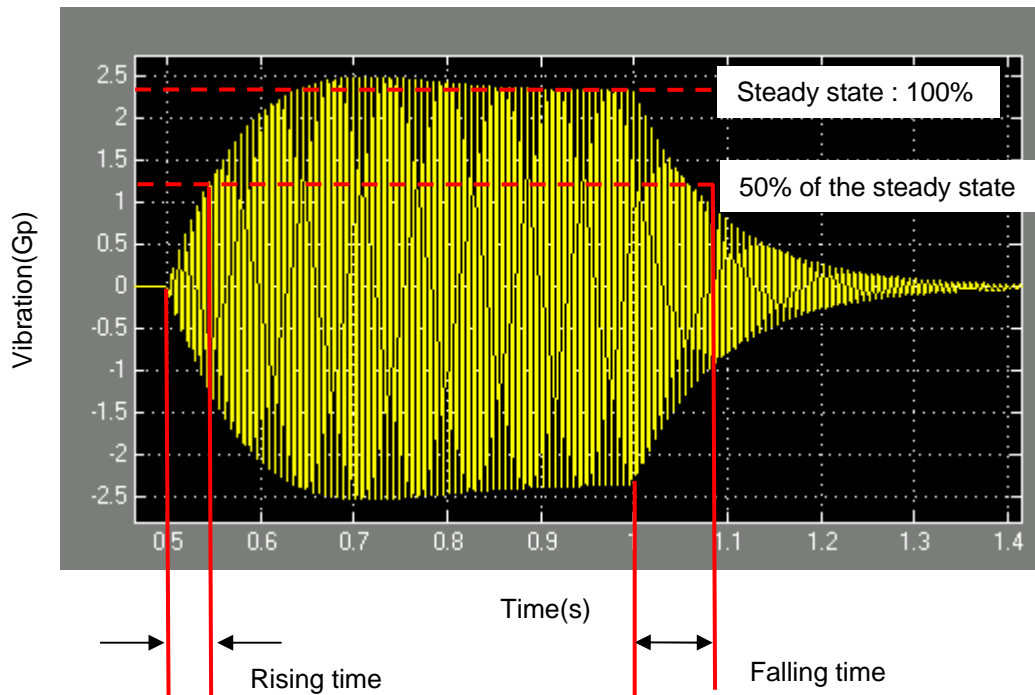

5.3 Acoustic noise

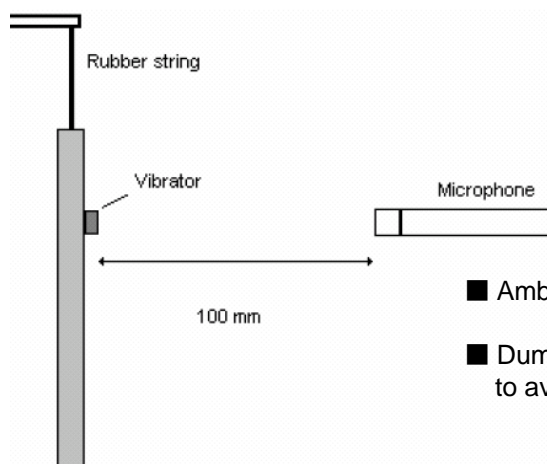

■ Ambient noise level : 23dB(A)

■ Dummy jig must be suspended by a rubber string to avoid disturbance.

Part Number		Company	Evowave	Approval No.	L10304A-0202
Specification	Φ10 x 3.0T	Name of applied Model	LG103020WXX	Enactment	2015.02.02
				Revision	

6. Outline drawings

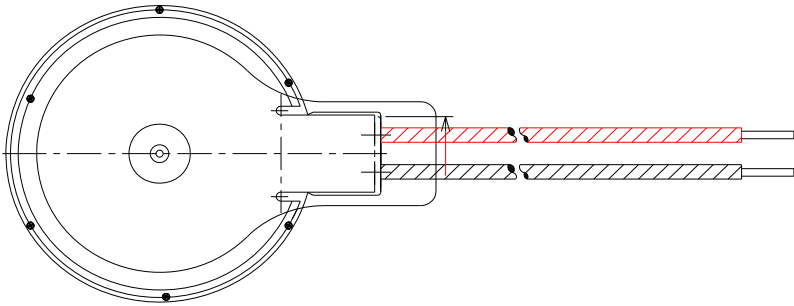
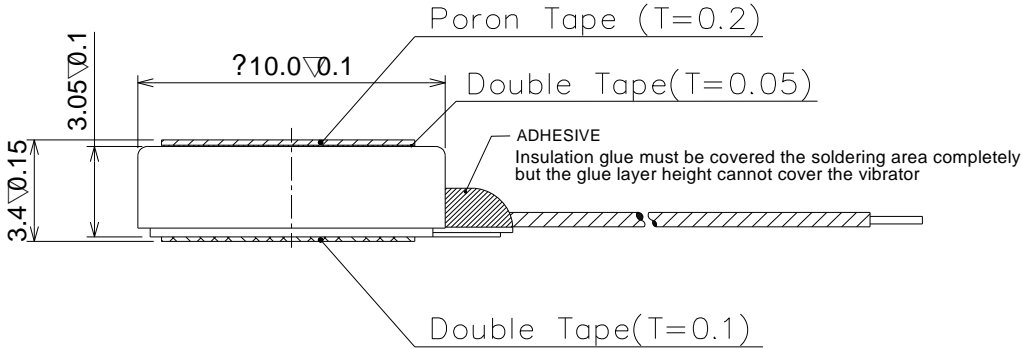
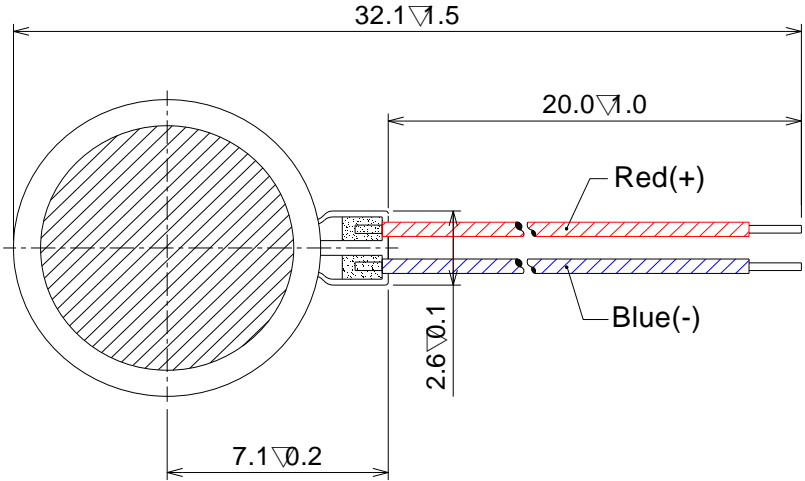

Part Number		Company	Evowave	Approval No.	L10304A-0202
Specification	Φ10 x 3.0T	Name of applied Model	LG103020WXX	Enactment	2015.02.02
				Revision	

7. Packing Specification

7.1 Packing Specification

Item	Tray	Inner Box	Out Box
Material	(PS) t=0.5mm	DW-1(Carton box)	DW-1(Carton box)
Dimension	330(L) x 235(W) x 7(H)	350(L) x 260(W) x 150(H)	370(L) x 540(W) x 320(H)
Quantity	100ea	2,000ea	8,000ea
Weight	Approximately (200g)	Approximately (4Kg)	Approximately 16Kg

7.2 Packing Drawing

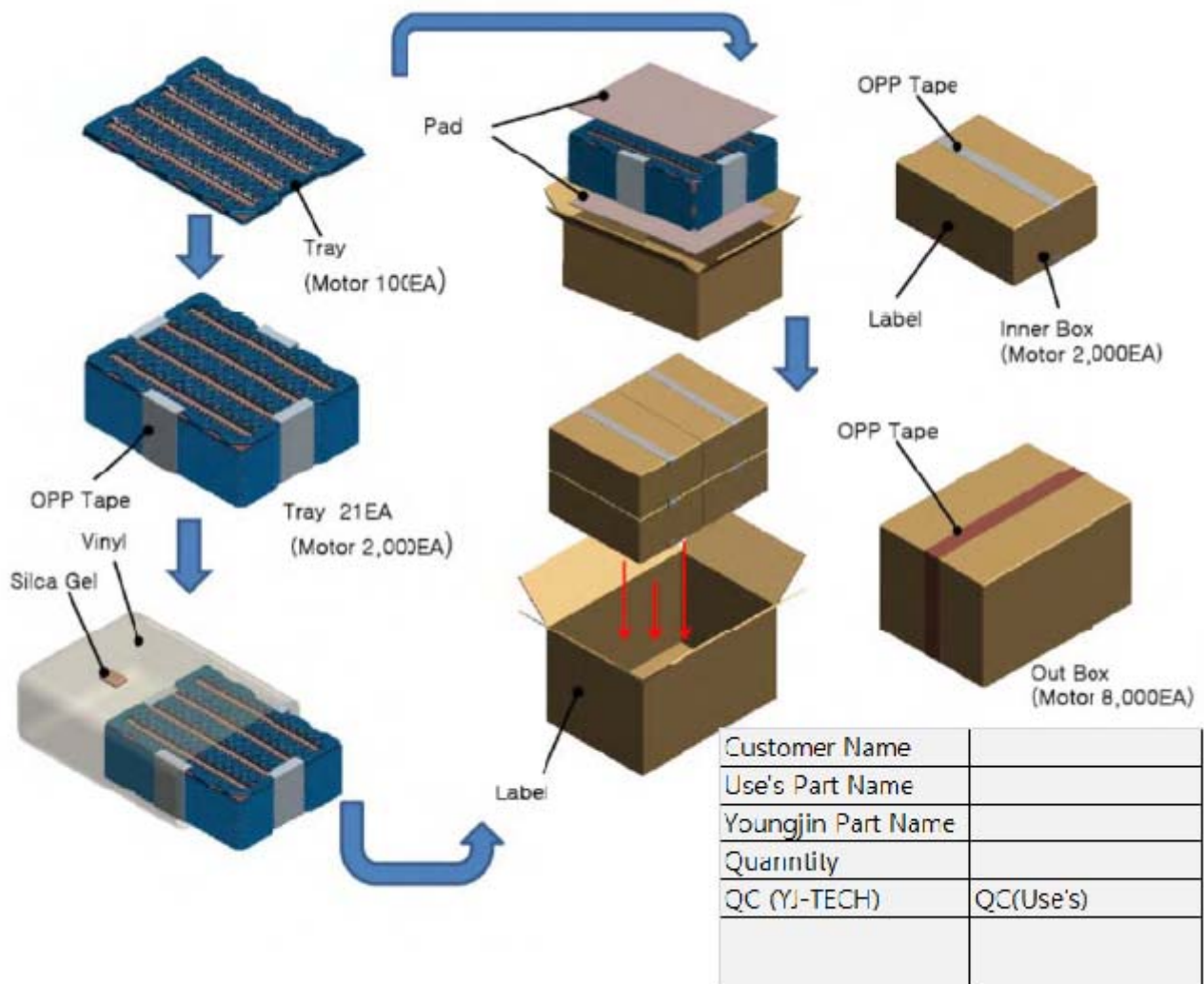

Part Number		Company	Evowave	Approval No.	L10304A-0202
Specification	Φ10 x 3.0T	Name of applied Model	LG103020WXX	Enactment	2015.02.02
				Revision	

8. Cautions

8.1 Allowable range for use

Unless it is used in accordance with the specifications, the performance and life may be considerably reduced. Due attention should be paid to the voltage and current ranges for use.

8.2 Storage

Avoid storing in high temperature, high humidity or corrosive gas environment.

8.3 Handling of vibrator

- Do not bring a magnetized object near or into contact with the surface because there is a fear of performance deterioration.
- Attention must be paid to the handling and working environments because incoming of magnetic particle into the vibrator cause noise, characteristic deterioration, thus reducing the reliability.
- Do not press the product with more than 0.5Kg.f. Strong pressing may cause the decrease of the performance or the deformation of the product.

Part Number		Company	Erowave	Approval No.	L10304A-0202
Specification	Φ10 x 3.0T	Name of applied Model	LG103020WXX	Enactment	2015.02.02
				Revision	