

維盟科技有限公司

EVOwave Technology Co., Ltd.

規格書 / Specification

Description:	Coin Type Vibrator
Part No.:	VK083015WXX
Date:	2015.4.23

地址: 新北市汐止區康寧街 169 巷 27 號 10 樓之 1

Address: 10F-1, No. 27, Lane 169, Kang-ning St., Xizhi district 221, Taipei, Taiwan.

Tel: 886-2-2692-6058

Fax: 886-2-2692-6659

## 規格書內容/ Contents

1. 適用範圍/General Scope of Application	1/8
2. 使用條件/Operating Conditions	1/8
3. 測定條件/Conditions of Measurement	1/8
4. 電氣性能/Electrical Characteristics	1/8
5. 機械性能/Mechanical Characteristics	2/8
6. 耐久性能/Reliability Test	2/8
7. 要求/Requirements after Reliability Tests	4/8
8. 使用注意事項/Cautions for Use	5/8
9. 包裝/Packaging Description	6/8
10. 外形圖/Outline Drawings	7/8
11. 更改記錄/Records of Revisions	8/8

## 1. 適用範圍/General Scope of Application

本說明書適用於扁平式永磁直流電機 VK083015WXX 系列。

This specification applies to coin type permanent-magnetic motors DC model VK083015WXX.

## 2. 使用條件/Operating Conditions

項目/Item	規格/Specifications	
2-1	額定電壓 Rated voltage	3.0V DC
2-2	使用電壓範圍 Operating voltage	2.7~3.3V DC
2-3	旋轉方向 Rotation	CW (clockwise) or CCW (counter clockwise)
2-4	使用環境 Operating environment	-20~60°C, 常濕/Ordinary Humidity:65±20%RH
2-5	保存環境 Storage environment	-30~70°C, 常濕/Ordinary Humidity:65±20%RH

## 3. 測定條件/Conditions of Measurement

項目/Item	規格/Specification	
3-1	溫度 Temperature	25±3°C
3-2	濕度 Humidity	65±20% RH
3-3	電源電壓 Power supply	穩壓直流電源 3.0V。 Constant Power supply 3.0V DC.

## 4. 電氣性能/Electrical Characteristics

項目/Item	規格/Specification	條件/Condition
4-1	額定轉速 Rated speed	額定電壓下。 At rated voltage.
4-2	額定電流 Rated current	
4-3	起動電流 Starting current	在最小起動電壓下起動。 Motor is rotating at minimum starting voltage.
4-4	起動電壓 Starting voltage	
4-5	絕緣電阻 Insulation resistance	在 100V 直流下，導線和機殼間。 At DC 100V between lead wire and case.
4-6	端子阻抗 Terminal resistance	在 25°C 下。 At 25°C

## 5. 機械性能/Mechanical Characteristics

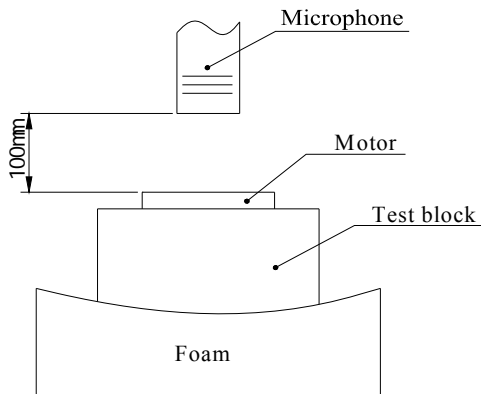
項目/Item	規格/Specification
5-1	底蓋偏轉強度 Bracket Deflection strength 9.8N 以上 9.8N or more.
5-2	機械噪音 Mechanical noise 小於 50 分貝. A 計權 50dB (A) Max. 在額定電壓下。At rated voltage. 背景噪音：不大於 28dB. A 計權. Back ground noise 28dB (A) Max. 

## 6. 耐久性能/ Reliability Tests

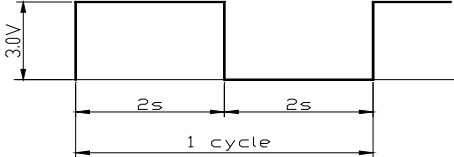
項目/Item	規格/Specification	判定標準/Judgment
6-1	壽命 Lifetime 額定電壓/ Rated voltage: 3.0V DC 試驗模式/ Test mode: 2s On, 2s Off, as one cycle. 迴圈次數/ Test cycle: 50,000 cycles 	試驗後，馬達應符合項 7-1 的要求。After the test, motors shall be approved as specified in item 7-1.
6-2	低溫放置 Low temperature exposure 溫度/Temperature: $-30^{\circ}\text{C}$ 時間/Time: 96h	常溫常濕下放置 4h 後，馬達應符合項 7-2 的要求。After 4 hours exposure in ordinary temperature and humidity, motors shall be approved as specified in item 7-2.
6-3	高溫放置 High temperature Exposure 溫度/Temperature: $+70^{\circ}\text{C}$ 時間/Time: 96h	常溫常濕下放置 4h 後，馬達應符合項 7-2 的要求。After 4 hours exposure in ordinary temperature and humidity, motors shall be approved as specified in item 7-2.

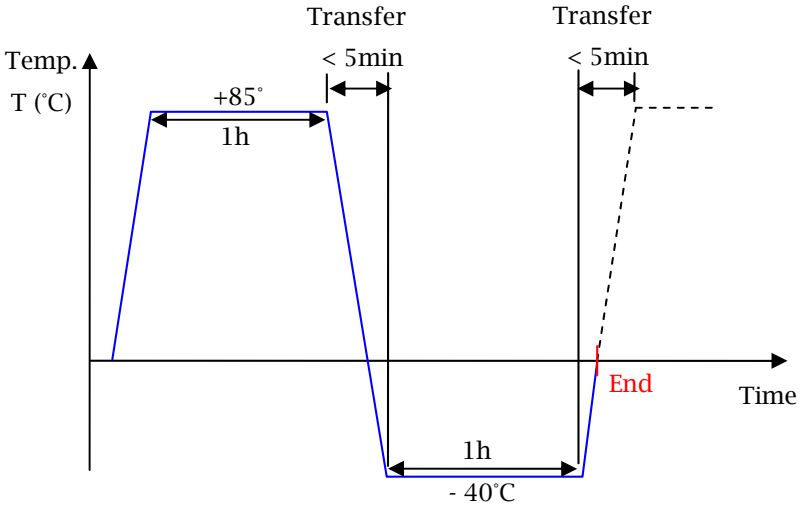
項目/Item	規格/Specification	判定標準/Judgment
6-4 濕度放置 High Humidity exposure	溫度/Temperature: +40°C 濕度/Humidity: 95%RH 放置時間/ Exposure time: 96h 無水氣凝結/ No condensation of moisture	常溫常濕下放置 4h 後，馬達應符合項 7-2 的要求。After 4 hours exposure in ordinary temperature and humidity, Motors shall be approved as specified in item 7-2.
6-5 振動 Vibration	全振幅/Displacement: 1.5mm (p-p) 頻率/Frequency: 10~55Hz 加速度/Acceleration: 22m/s <sup>2</sup> 週期/Period: 10 分鐘範圍內 (10~55~10Hz)/ 10 Minutes log sweep (10~55~10Hz) 條件/Condition: 在樣機中，在 3 個垂直的軸方向每個方向做 10 分鐘的測試。Samples shall be applied for a period of 10 minutes in three axial directions.	測試結果應符合項 7-2 的要求。After the test motors shall be approved as specified in item 7-2.
6-6 自然跌落 Free fall	試驗狀態/Test mode: 將馬達固定在約 100 克 (包括馬達本身) 的物體上，落向水泥地面。Set the motor to a fixture of approx. 100g (include the motor) and drop it onto the concrete floor. 高度/Height: 1.5m 方向/Direction: ±x, ±y, ±z 次數/Number of times: 每個方向 3 次/ Each 3 times	測試結果應符合項 7-2 的要求。After the test motors shall be approved as specified in item 7-2.
6-7 熱衝擊 Thermal shock	測試模式/ Test mode: 1 hour at -40°C, 1 hour at +85°C, as one cycle. Transfer time between extreme temperatures: < 5 分/5min 迴圈次數/Test cycle: 15 cycles 	常溫常濕下放置 4h 後，馬達應符合項 7-2 的要求。After 4 hours exposure in ordinary temperature and humidity, Motors shall be approved as specified in item 7-2.

## 7. 判定基準/ Judgments after Reliability Tests

項目/Item		判定基準/Requirements
7-1	表 A Table A	1)額定轉速/Rated speed: 不低於初始值-30%；不高於初始值+50%/ No lower than -30% of initial data; No more than +50% of initial data. 2)額定電流/Rated current: 不低於初始值-30%；不高於初始值+50% No lower than -30% of initial data; No more than +50% of initial data. 3)端阻/Terminal resistance: 不大於初始值±15% No more than +15% of initial data; No less than -15% of initial data. 4)起動電壓/Starting voltage: 不大於 2.5V 直流電壓 2.5V DC Max 5)絕緣電阻/Insulation resistance: 大於 10MΩ/ 10MΩ Min
7-2	表 B Table B	1)額定轉速/Rated speed: 不大於初始值±20% No more than +20% of initial data; No less than -20% of initial data. 2)額定電流/Rated current: 不大於初始值±20% No more than +20% of initial data; No less than -20% of initial data. 3)起動電壓/Starting voltage: 不大於 2.5V 直流電壓 2.5V DC Max 4)端阻/Terminal resistance: 不大於初始值±15% No more than +15% of initial data; No less than -15% of initial data.

## 8. 使用時注意事項/ Cautions for Use

8-1 必須按照規格書標準使用，否則性能和壽命都將受到相當地減少，必須注意電壓的使用範圍。  
Unless it is used in accordance with the specifications, the performance and life may be considerably reduced. Due attention should be paid to voltage and range for use.

8-2 建議馬達在六個月內使用，不要在以下環境中使用及保存：

1. 高溫和高濕的場所；
2. 腐蝕性氣體,如：H<sub>2</sub>S、SO<sub>2</sub>、NO<sub>2</sub>、Cl<sub>2</sub>；
3. 生鏽場所。

Advice uses this motor within 6 months as avoiding as possible.

Avoid use or save the motor in the following environment.

1. High temperature and high humidity area
2. Corrosive gas such as H<sub>2</sub>S, SO<sub>2</sub>, NO<sub>2</sub>, Cl<sub>2</sub>.
3. Dusty area.

8-3 注意處理馬達的工作環境，避免含鐵質等物體被馬達吸住，否則馬達將會產生雜訊，性能會降低，從而減少產品可靠性。

Due attention must be paid to the handling and working environments because such objects as iron powder if attracted by the motor magnet, will cause noise, characteristic deterioration thus reducing the reliability.

8-4 應確信本產品不會與相關標準、法律、政令相背。

Please confirm enough no problems of standards and laws and ordinances on your cellular phone.

8-5 拿馬達時，要輕拿輕放。

To handle the motor, hold the motor case softly.

8-6 鋼板面或邊緣有少許鏽斑是允許的。

Rust of plate (steel) and similar edge should be OK.

8-7 我司遵循持續發展的策略，在不預先通知的情況下，有對產品（部品）進行修改和改進的權利，當然這些都不會影響馬達的特性及使用功能。

Our company follows the sustainable developing strategy, and have the right to make changes and improvements to our product without giving notice in advance. Of course, these changes and improvements will not affect the characteristics and function of the motor.

Our company follows the sustainable developing strategy, and have the right to make changes and improvements to our product without giving notice in advance. Of course, these changes and improvements will not affect the characteristics and function of the motor.

9. 包裝/PACKING

扁平系列馬達包裝  
Pack drawing of coin type

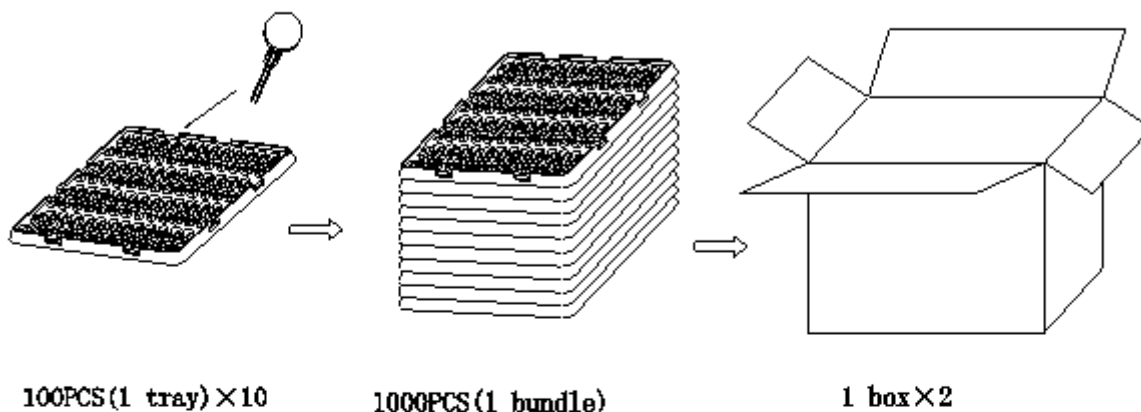

Remarks:  
4000PCS/CTN: 45cm x 28cm x 20cm  
6000PCS/CTN: 45cm x 28cm x 30cm

包裝試驗要求:  
沿外包裝箱±x, ±y和±z方向, 距水泥地面1.5m高度, 各自由  
跌落2次, 馬達應無機械損傷, 電氣  
性能仍符合標準要求。

Drop Test with carton:  
Drop the carton in the axial directions  
of ±x, ±y, ±z onto the concrete floor  
from 1.5m height, drop twice each  
direction. After drop test, no  
mechanical damage to motors, and  
the electrical performances remain  
unchanged.

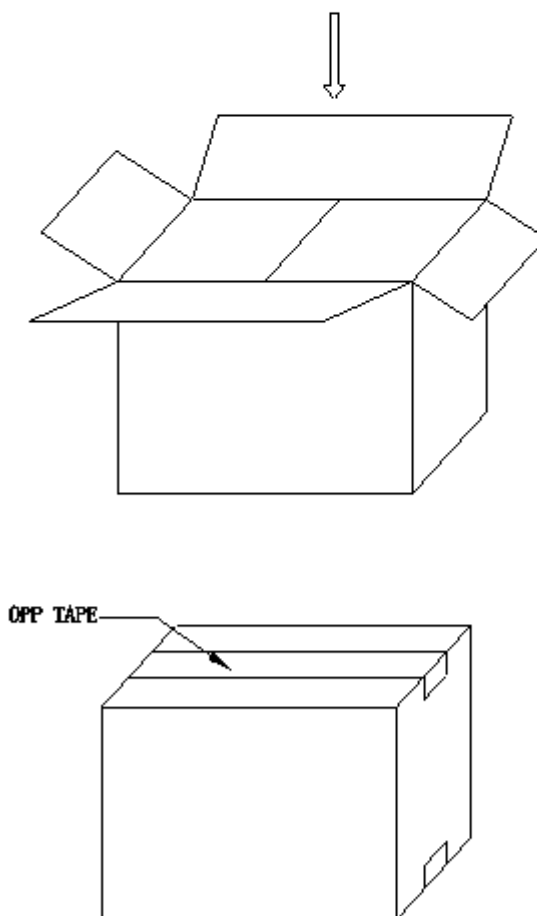



10. 外形圖/ OUTLINE DRAWINGS

