



維盟科技有限公司  
EVOwave Technology Co., Ltd.

規格書 / Specification

Description:	Spring Type Vibrator
Part No.:	VK0610SXX
Date:	2015.4.13

地址: 新北市汐止區康寧街 169 巷 27 號 10 樓之 1

Address: 10F-1, No. 27, Lane 169, Kang-ning St., Xizhi district 221, Taipei, Taiwan.

Tel: 886-2-2692-6058

Fax: 886-2-2692-6659

## 規格書內容/Contents

1、適用範圍/ General Scope	3/9
2、使用條件/ Operating Conditions	3/9
3、測定條件/ Measuring Conditions	3/9
4、機械要求/ Mechanical Specifications	3/9
5、性能特徵/Performance and characteristics	4/9
6、可靠性/Reliability	5/9
7、要求/Requirements	6/9
8、使用時注意事項/ attentions	6/9
9、包裝/Packaging	7/9
10、外形圖/Outline Drawing	8/9
11、修改記錄 / REVISION HISTORY	9/9

### 1. 適用範圍/ General Scope

本說明書適用於圓筒式永磁直流電機 VK0610SXX 型

This specification applies to cylindrical permanent-magnetic motors DC model VK0610SXX

### 2. 使用條件/ Operating Conditions

項目/Item		規格/Specifications	條件·備註/Conditions & Remarks
2-1	額定電壓 Rated voltage	3.0V DC	
2-2	額定負荷 Rated load	振子 Counterweight	見 10. 外形圖 As specified in 10. Outline Drawing
2-3	旋轉方向 Rotation	C.W/C.C.W (clockwise or counter clockwise)	
2-4	馬達位置 Motor position	全方位 All position	
2-5	使用電壓範圍 Operating voltage	2.2~3.6V DC	
2-6	使用環境 Operating environment	-30 ~ 70 °C , 常 濕 /Ordinary Humidity:65±20%RH	無水氣凝結 No condensation of moisture
2-7	保存環境 Storage environment	-40 ~ 80 °C , 常 濕 /Ordinary Humidity:65±20%RH	無水氣凝結 No condensation of moisture

### 3 · 測定條件/Measuring condition

項目/Item		規格/Specifications	條件·備註/Conditions & Remarks
3-1	溫度 Temperature	20±2°C	
3-2	濕度 Humidity	( 63%~67% ) RH	
3-3	位置 Motor position	軸向水準 Motor shaft horizontal	將馬達固定在試驗臺上 Lock the motor in a test fixture

標準測試條件為溫度 20°C，濕度 65%。如無疑異，也可在溫度 5~35°C、濕度 45~85%的條件下測試。馬達測試時，放置方向為軸向水準。/The measurement at 20°C & 65%RH is standard. If the judgment is not questionable, recognize measurement at 5°C to 35°C & relative humidity 45% to 85%. Direction of motor is shaft horizontal.

### 4 · 機械要求/ Mechanical specification

項目/Item		規格/Specifications	條件·備註/Conditions & Remarks
4-1	結構 Configuration	見 10. 外形圖 As specified in 10. Outline Drawing	Outline drawing No: VK0610SXX
4-2	外觀 Appearance	不含有機械損壞及不適當的浸蝕等。 There shall be no evidence of mechanical damage and shall not have inadequate corrosion and so on	目測（容許範圍根據樣品外形） Visual examination(allowable extent is based on boundary sample)
4-3	軸向間隙 Shaft end play	0.1mm~0.3mm	
4-4	振子固定力 Holding strength of vibration weight	49N (5kgf) Min	

5.性能特徵/Performance and characteristics

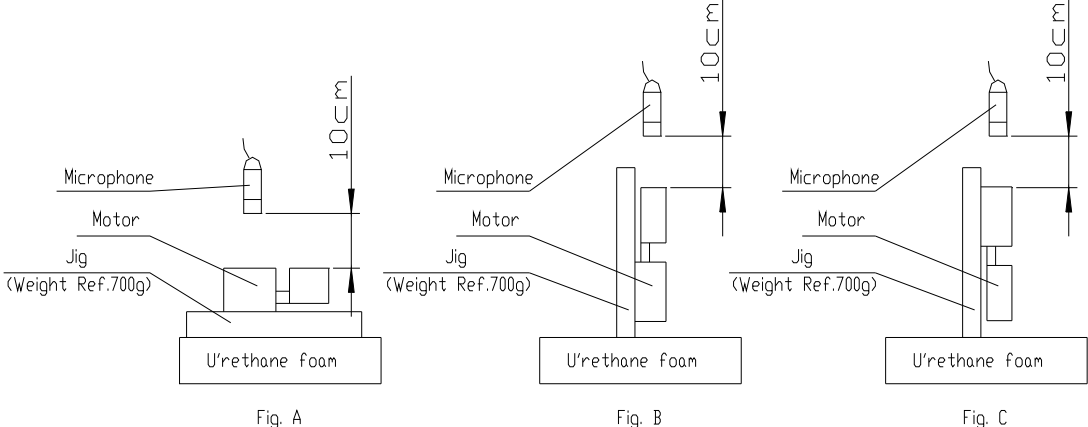
項目/Item	規格/Specifications	條件·備註/Conditions & Remarks
5-1 額定轉速 Rated speed	8,000±2,000rpm	在額定電壓和額定負載（振子）下。 At rated voltage and rated load (vibration weight).
5-2 額定電流 Rated current	75 mA Max	
5-3 堵轉電流 Stall current	105 mA Max	在額定電壓下 At rated voltage
5-4 起動電壓 Starting voltage	1.7V DC Max	在額定負載（振子）下電樞的任意位置。 At rated load (Counterweight) any position of rotor.
5-5 絕緣電阻 Insulation resistance	1MΩ Min	在 100V 直流下，端子和機殼間 At DC 100V between Terminal and case.
5-6 端子阻抗 Terminal resistance	35Ω (±20%)	在 20°C 下 At 20°C
5-7 機械噪音 Mechanical noise	50db(A) Max	<p>在額定電壓、額定負載（振子）下 背景雜音：不大於 28dB.A 計權 測試儀器：B&amp;k 夾具重量：700g At rated voltage and rated load (Counterweight). Back ground noise 28dB(A) Max Measuring instruments: B&amp;k Weight of jig:700g</p> 

6 · 可靠性/Reliability

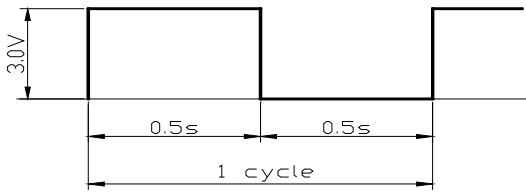
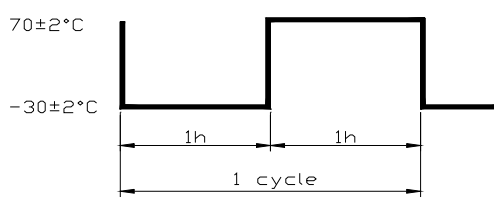
項目/Item		規格/Specification						判定標準/Judgment
6-1	壽命 Life time							在常溫常濕下放置 2h 後，馬達應符合項 7-1 的要求。 After 2 hours exposure in ordinary temperature and humidity, Motors shall be approved as specified in item 7-1.
		位置 Position	電壓 Volt	負荷 Load	溫度 Temp	濕度 Humi	壽命 Life	
		軸水準 Horizon	額定 Rated	重量 Weight 振子	20°C	65%	200,000 Cycles	
6-2	低溫放置 Low temp exposure	溫度 /Temperature: $-40\pm 2^{\circ}\text{C}$ 時間 /Time: 96h						在常溫常濕下放置 2h 後，馬達應符合項 7-2 的要求。 After 2 hours exposure in ordinary temperature and humidity, Motors shall be approved as specified in item 7-2.
6-3	高溫放置 High temp. Exposure	溫度 /Temperature: $60\pm 2^{\circ}\text{C}$ 時間 /Time: 96h						
6-4	濕度放置 Humidity exposure	溫度 /Temperature: $40\pm 2^{\circ}\text{C}$ 濕度 /Humidity: 90~95%RH 放置時間 /Exposure time: 96h 無水氣凝結/No condensation of moisture						
6-5	振動 Vibration	頻率 /Frequency: 10~55~10Hz 全振幅 /Displacement: 1.5mm (p-p) 加速度 /Acceleration: $22\text{m/s}^2$ 週期 /Period: 20min 完成 10~55~10Hz /20 Minutes log sweep 10~55~10Hz 方向 /Direction: x, y, z 時間 /Time: 每個方向 2h /Each 2 hours						測試結果應符合項 7-2 的要求。 After the test motors shall be approved as specified in item 7-2.
6-6	自然跌落 Free fall	試驗狀態/Test state: 將馬達固定在約 75 克 (包括馬達本身) 的物體上，落向水泥地面。 Set the motor to the approximately 75g (include the motor) weight of block drop the motor on the concrete floor. 高度 /Height: 1.5m 方向 /Direction: 6 個面 / 6 faces 次數 /Number of times: 每個面 2 次 / Twice 2 each						測試結果應符合項 7-2 的要求。 After the test motors shall be approved as specified in item 7-2.
6-7	熱衝擊 Heat shock test	試驗迴圈 /Test cycle :20 cycles 						在常溫常濕下放置 2h 後，馬達應符合項 7-2 的要求。 After 2 hours exposure in ordinary temperature and humidity, Motors shall be approved as specified in item 7-2.

## 7. 要求/Requirements

項目/Item		判定基準/Requirements
7-1	表 A Table A	1) 額定轉速/Rated speed: 不低於初始值-30%,不高於初始值+60% Initial data -30% Min, Initial data +60% Max 2) 額定電流/Rated current: 不大於初始值±30%/Initial data±30% max 3) 起動電壓/Starting voltage: 2.0V DC Max
7-2	表 B Table B	1) 額定轉速/Rated speed: 不大於初始值±30%/Initial data±30% max 2) 額定電流/Rated current: 不大於初始值±30%/Initial data±30% max 3) 起動電壓/Starting voltage: 2.0V DC Max

## 8. 使用時注意事項/Matters to be paid attention to when using motor

8-1 電機在運輸過程中應小心輕放，避免嚴重碰撞敲擊引起的電機機身和性能受損。(Please lay the motors carefully in transportation to avoid any serious damage to the motor body or its electric function because of collision.)

8-2 請按照規格書中規定的第 2 條(使用條件)來使用和存儲電機，否則會影響電機性能。(Please use and storage motors according to N0.2 item (Operating Conditions) in specification, or else motor characteristics would be affected.)

8-3 請在 6 個月內使用。在使用和打開馬達外包裝時請避免水氣凝結。(Make arrangement to limit the storage period to 6 months or less. Condensation of atmosphere must be avoided in motor usage or opening the packaging of the motor.)

8-4 馬達應適當的操作、儲存和運轉環境中均不可存在腐蝕性氣體。例如：H<sub>2</sub>S、SO<sub>2</sub>、NO<sub>2</sub>、CL<sub>2</sub> 等。另外存儲環境中不可有諸如矽、氰、甲醛水和苯酚等能放射出腐蝕性氣體的物質，在電機的機械構造或裝置中，如果存在腐蝕性氣體，那麼這會引起馬達不運轉。(For proper operation, storage and operating environment must not contain corrosive gases. For example H<sub>2</sub>S, SO<sub>2</sub>, NO<sub>2</sub>, CL<sub>2</sub>, etc. In addition storage environment must not have materials that emit corrosive gases especially from silicon, cyanic, formalin and phenol group. In the mechanism or the set, existence of corrosive gases may cause no rotation in motor.)

8-5 請通電後不要長時間堵住機軸，並且馬達轉動時不要觸碰振子。(Please don't stall the shaft for a long time after powering, and not to touch the weight when motor is rotating.)

8-6 馬達軸向間隙處不應有雜物（如顆粒、纖維物、頭髮、膠帶、膠水等）(There should be no sundries (such as grain, fibre, hair, small tape, glue etc.) in the shaft end play.)

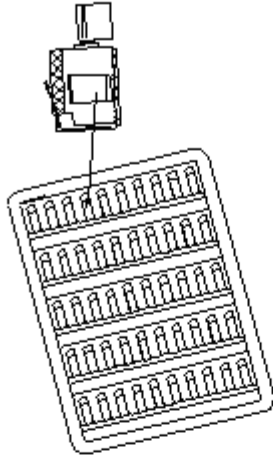

50PCS (1 tray) × 10

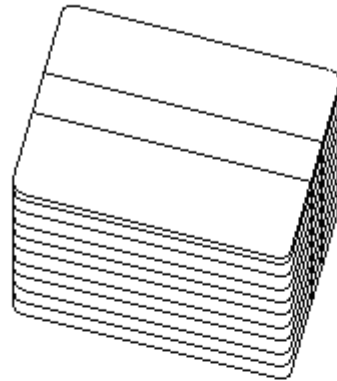

500PCS (1 bundle) × 6

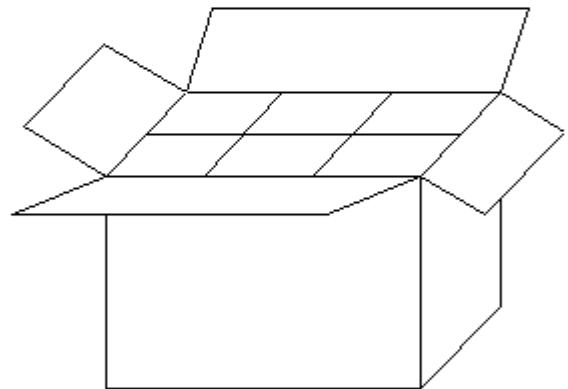

**包装试验要求**

**1. 标准**

- (1) 整箱重量小于等于9kg的，跌落高度设定为75cm。
- (2) 整箱重量大于9kg但小于等于23kg的，跌落高度设定为60cm。

**2. 试验方法：**

跌落要求为六面三棱一角。

- (1) 六面：先从最大两面跌，然后是中间大小的两面，最后跌最小的两面，一共六次。
- (2) 三棱：指任选三条同一角的棱，跌落顺序，最长棱，中间长度，最短的，一共三次。
- (3) 一角：指上一步三条棱所组成的角，跌落一次。

**3. 判定基准**

经过跌落试验后，产品外观、性能无不良。

**Package Test Requirement:**

**1. Criteria**

- (1) The weight of the whole carton less than 9kg, the dropping height is 75cm.
- (2) The weight of the whole carton more than 9kg and less than 23kg, the dropping height is 60cm.

**2. Test Methods:**

Dropping requirement is 6 faces, 3 arris, 1 angle.

- (1) 6 faces: First dropping with two biggest faces, then dropping with another two middle faces, at last dropping with two smallest faces, once per face, total 6 faces.
- (2) 3 arris: Choose any 3 arris which make up of the same the angle, the dropping sequence is the longest arris, middle arris, shortest arris. Total 3 times.
- (3) 1 angle: Point to the angle which is made up with the 3 arris in the above step. Dropping for 1 times.

**3. Judgement Criterion**

After drop test, no evidence of damage on the appearance and performance.

**Remarks:**

- 1000PCS/CTN: 24cm × 17.5cm × 27.5cm
- 2000PCS/CTN: 34cm × 24cm × 27.5cm
- 4000PCS/CTN: 47cm × 34cm × 27.5cm
- 6000PCS/CTN: 54cm × 47cm × 27.5cm

OPP TAPE

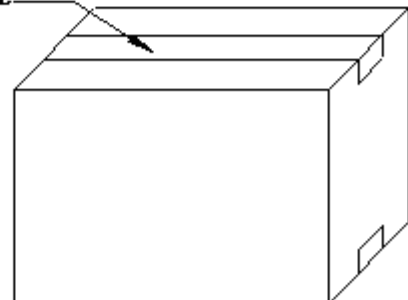



10. 外形圖/Outline Drawing

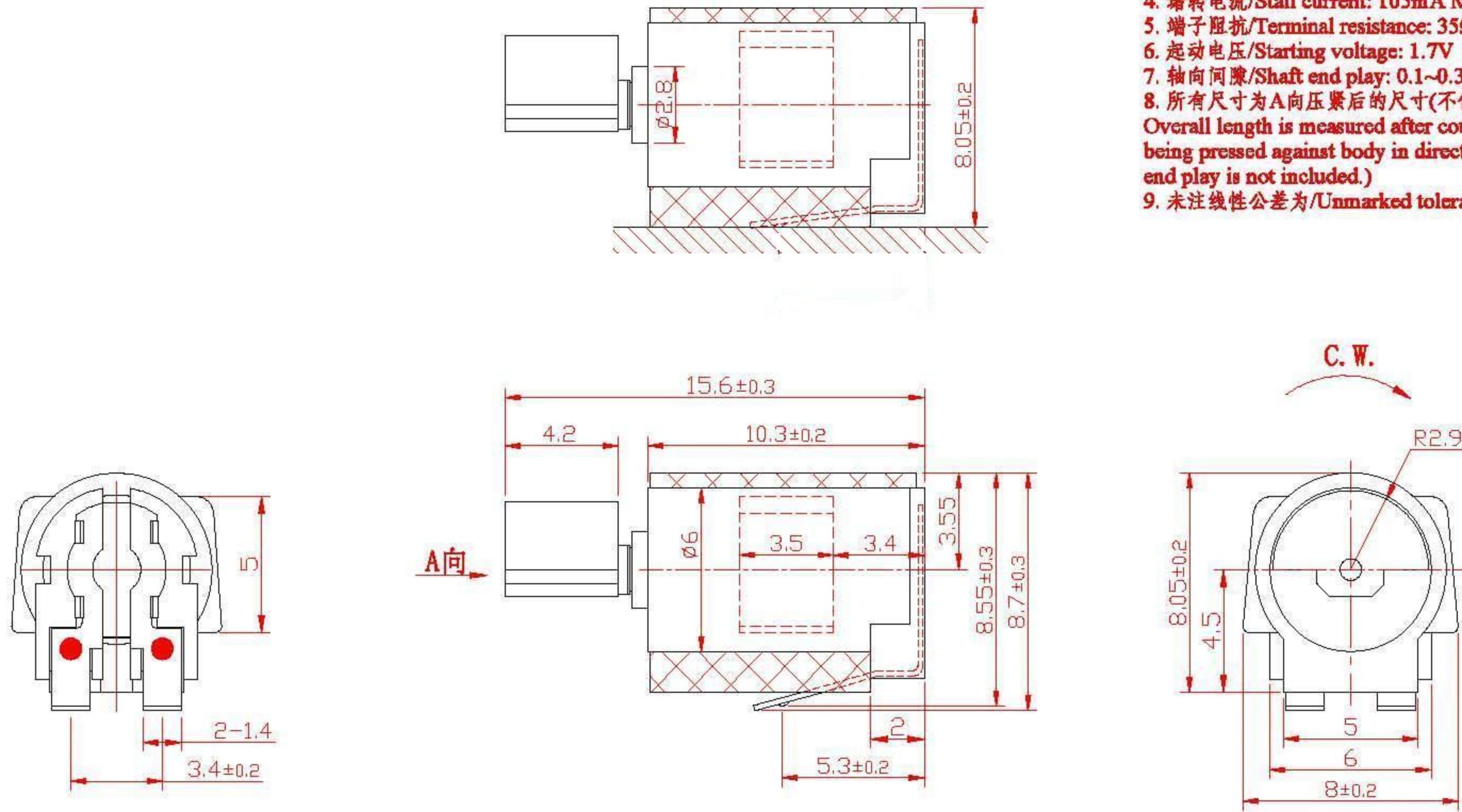

技术要求/Technical Requirements:

1. 额定电压/Rated voltage: 3.0V
2. 额定电流/Rated current: 75mA Max
3. 额定转速/Rated speed: 8,000 ± 2000rpm
4. 堵转电流/Stall current: 105mA Max
5. 端子阻抗/Terminal resistance: 35Ω(±20%)
6. 起动电压/Starting voltage: 1.7V Max
7. 轴向间隙/Shaft end play: 0.1~0.3mm
8. 所有尺寸为A向压紧后的尺寸(不包括轴向间隙)/  
Overall length is measured after counterweight  
being pressed against body in direction A. (Shaft  
end play is not included.)
9. 未注线性公差为/Unmarked tolerance: ± 0.1mm

借(通)用件登记

底图总号

签字

日期

						維盟科技有限公司		
						外形图		
标记	处数	分区	更改文件号	签名	日期	阶段标记	重量	比例
设计	郭梦秋	2009.08.18	标准化					5:1
校对	汪丰华	2009.08.18						
审核	郑景涛	2009.08.18						
工艺	刘林兵	2009.08.18	批准	项瑞整	2009.08.18	共 页	第 页	



