



維盟科技有限公司
Ewowave Technology Co., Ltd.

規格書 / Specification

Description:	BLDC Vibration Motor
Part No.:	VG0825R10WXX
Date:	2015/07/29

地址:新北市汐止區康寧街 169 巷 27 號 10 樓之 1

Address: 10F-1, No.27, Lane 169, Kang-ning St., Hsi Chih
221, Taipei, Taiwan.

Tel: 886-2-2692-6058

Fax: 886-2-2692-6659

※규격 목차 ※

NO	ITEM	Page
1	변경이력 / Revision History	3
2	적용범위 /Application	4
3	표준사용조건 /Standard Operating Condition	4
4	표준측정조건 /Standard Measurement Condition	4
5	판정환경조건 / Judgment Environmental Condition	5
6	시험오차범위 / Test Tolerance	5
7	전기적 특성 /Electrical Characteristics	5
8	기계적 특성 / Mechanical Characteristics	6
9	특성 그래프 / Graph Characteristic Graph	5
10	신뢰성 시험 / Reliability Test	7~8
11	구성도 / Composition Draw	9
12	포장 / Packing	10~11
13	주의사항 / Caution	12
14	사양변경 / Specification Change	13
15	안전규격 / Safety Standard	13
16	고장율 / Failure rate	13
17	도면 / Drawing	14

Part Number		Company	EVOWAVE	Approval No.	B0825R-0710
Specification	Φ8 x 2.5T	Name of applied Model	VG0825R10WXX	Enactment	2015.07.10
				Revision	

1. 이력 REVISION HISTORY

REV No.	Date	Description	Inspector	Designed	Approved
00	2015.07.10	New			T.B PARK

Part Number		Company	EVOWAVE	Approval No.	B0825R-0710
Specification	Φ8 x 2.5T	Name of applied Model	VG0825R10WXX	Enactment	2015.07.10
				Revision	

2. 적용/ Scope

본 사양은 영진 하이텍에서 생산하는 motor로 Pager or 휴대폰용으로 VG0825R10WXX 진동 Motor에 적용된다.

This specification is applies to VG0825R10WXX vibration motors to be used for pagers or mobile telephone.

3. 목차/ Contents

No.	Item	Specification
3-1	사용전압범위 Operating Voltage Range	DC 2.5V ~ 4.0V
3-2	보존온도범위 Storage Temperature Range	(-)40 ~ (+)85℃
3-3	사용온도범위 Operating Temperature Range	(-)30 ~ (+)60℃ 그러나, -30℃에서 +25℃에비해 7-3항 정격 회전수 약 45%감소 현상 있습니다 However, there is 45% decrease of rated load speed of the section 7-3 at -30℃ compared to +25℃.
3-4	사용위치 Operating Position	전 방향 All Direction

4. 표준시험조건/ Standard Test Condition

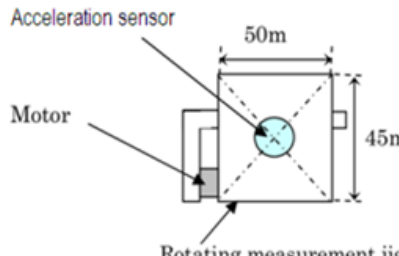
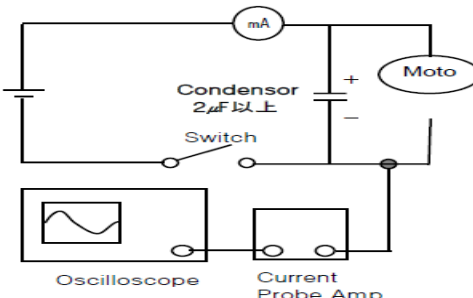
No.	Item	Specification
4-1	온도 Temperature	25±3℃
4-2	습도 Humidity	65%±20% RH
4-3	측정전압 Measurement Voltage	DC3.0V
4-4	<div style="display: flex; justify-content: space-around;"> <div style="text-align: center;">  <p>표준 측정 상태 Standard Measurement State</p> </div> <div style="text-align: center;">  <p>검사회로도 Inspection Circuit Diagram</p> </div> </div> <p>- Jig : 50x46x45mm [Material is POM] - Weight: 150g - The vibrator is Clamped firmly (0.5~1Kg pressure) on a test fixture</p>	

Part Number		Company	EVOWAVE	Approval No.	B0825R-0710
Specification	Φ8 x 2.5T	Name of applied Model	VG0825R10WXX	Enactment	2015.07.10
				Revision	

5. 판정환경조건 Judgment Environmental Condition

NO	Item	Condition
5-1	온도 Temperature	25±3℃
5-2	습도 Humidity	65%±20%RH

6. 시험오차범위 Test Tolerance

시험 조건이나 장비는 별도 지정이 없는 한 다음의 조건을 만족 해야 한다.

Test set-ups and equipment shall be capable of maintaining following condition, unless otherwise specified.

NO	Item	Condition
6-1	상온/상습 Room Temperature & Humidity	20±15℃ /65±20%RH
6-2	항온조 온도 Test Chamber Temperature	Limits ±3℃
6-3	전압 Voltage	Limits ±0.15V

7. 전기적 특성 Electrical Characteristics

No	Item	Test Condition	Condition
7-1	정격전압/ Rated Voltage	.	DC 3.0V
7-2	회전방향/ Rotating Direction	CW [Lead Wire Red(+), Black(-)에 연결기준] CW [Lead Wire Red to (+), Black to (-)]	CW
7-3	정격 회전수 / Rated Load Speed	4항의 표준측정조건기준으로 한다	15,000 ± 3,500 rpm
7-4	정격전류/ Rated Load Current	It is based on the standard measurement condition of the section 4.	80 mA max
7-5	기동전류 /Starting Current		150 mA max
7-6	Rising Time (진동력 50%)		80 ms max
7-7	Falling Time(진동력 50%)		80 ms max
7-8	기동전압 /Starting Voltage		Motor를 4-1, 4-2, 4-4항의표준측정 조건에서 On/Off . Motor On/Off test based on the standard measurement condition of the section 4-1, 4-2, and 4-4.
7-9	절연전압/ Insulation Voltage	단자와 모터의 Case 사이를 절연 저항계로 DC100V 메가로 측정 . Measured between terminal and case with DC100V Megger .	10 MΩ min

Part Number		Company	EVOWAVE	Approval No.	B0825R-0710
Specification	Φ8 x 2.5T	Name of applied Model	VG0825R10WXX	Enactment	2015.07.10
				Revision	

8. 기계적특성 Mechanical Characteristics

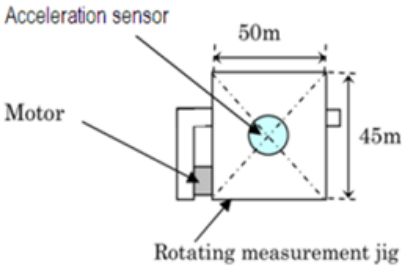
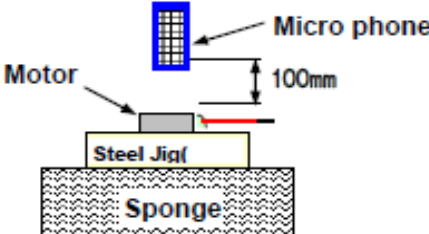
NO	Item	Specification	Condition
8-1	진동력 Vibration Force	<ul style="list-style-type: none"> - 50x46x45mm [Material is POM] - Weight : 150g -The vibrator is Clamped firmly (0.5~1Kg pressure) on a test fixture, 	<p>7-3항의 회전수에 준한다. It is referred to the rated load speed of the section 7-3</p>
8-2	기계적 소음 Mechanical Noise	<ul style="list-style-type: none"> - 고정방법:모터는 양면Tape에의해 지그에 고정된다 - Motor shall be fixed on Jig by adhesive tape - 지그재질은 SUS-304이다 - Jig Material 	<p>50dB 이하. 50dB MAX * 암소음 24dB 이하</p>
8-3	중량 Weight		약 0.90g about 0.90g

9. 특성 Graph. Characteristic Graph

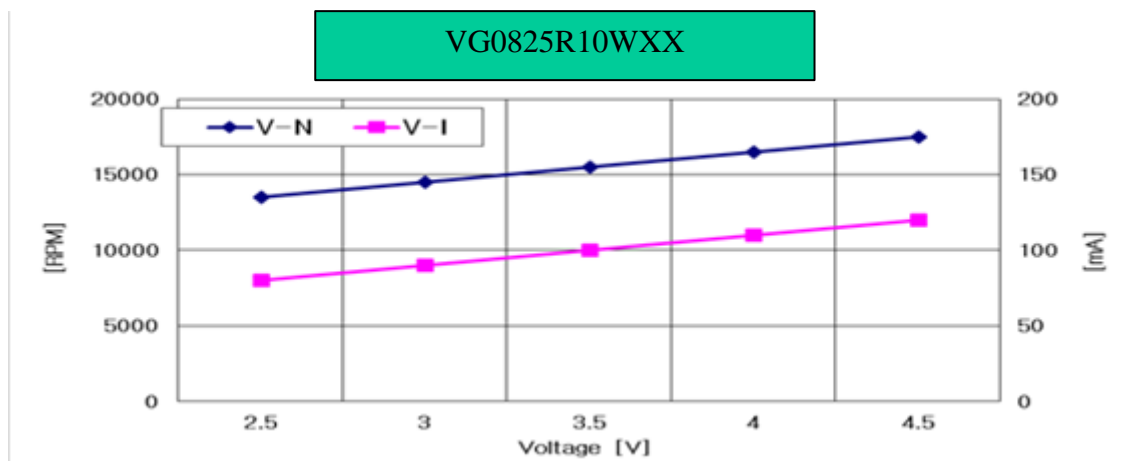

Part Number		Company	EVOWAVE	Approval No.	B0825R-0710
Specification	Φ8 x 2.5T	Name of applied Model	VG0825R10WXX	Enactment	2015.07.10
				Revision	

10. 신뢰성 시험 Reliability Test

NO	Item	Test Condition			Specification
		Item	상온회전수명 Room Temp. & Humi. L/T	고온고습회전수명 High Temp. & Humi. L/T	
10-1	상온회전수명 Room Temperature & Humidity Life Test				-정격 회전수 : 초기치에 +40, -20% -Rated Load Speed: Initial value +40, -20% 또는 정격 회전수 내 Or within rated load speed -정격전류: 초기치에 ±30% -Rated Load Current: Initial value ±30% --기타 The others: 7-6,7-7항의 조건에 따른다 - The others: Conform to the section 7-6 and 7-7.
10-2	고온고습회전수명 High Temperature & Humidity Life Test	Voltage	DC 3.0V	DC 3.0V	
		Temperature	20±15℃	40℃	
		Humidity	65±20% RH	90% RH	
		Life cycles	1,000,000 cycles	300,000 cycles	
		Duty Cycle	0.5 sec ON / 0.5 sec OFF	0.5 sec ON / 0.5 sec OFF Motor shall be fixed on Jig by adhesive tape. (Refer to the section 4-4)	
10-3	고온고습통전 (복합시험) Composite Test	정격 전압, 정격 부하에서 20 ℃ 65 % RH, 10 시간 연속 운전시킨 후 60 ℃ 90 % RH에서 500h 방치한다. Conduct the continuous running for 10 hours as following Then storage at 60℃ 90% for 500hours			-정격회전수 : 정격 회전수 또는 초기치에 +40, -20% -정격전류 : 초기치에 ±30%
10-4	저온방치시험 Low Temperature Storage Performance	-40℃, 500시간 저온 보관후 상온 상습에서 4시간 방치후 측정. Exposed to -40℃ for 500 hours and then room temperature for 4 hours.			-정격 회전수: 정격 회전수 또는 초기치에 ±20% (Rated Load Speed: Initial value ±20%, or within rated load speed)
10-5	고온 방치시험 High Temperature Storage Performance	-85 ℃, 60 % RH 500 시간 보관 후 상온 상습에서 4 시간 방치 후 측정 -Exposed to +85℃, 60%RH for 500 hours and then room temperature for 4 hours.			-정격전류: 초기치에 +20% (Rated Load Current: Initial value +20%) -기타 The others: 7-6,7-7항의 조건에 따른다 (Conform to the section 7-6 and 7-7.)
10-6	고온고습방치시험 High Temperature and Humidity Storage Performance	-온도 60 ℃, 습도 90 % RH에서 500 시간 방치 상온 상습에서 4 시간 방치 후 측정 -Exposed to +60℃, 90%RH for 500 hours and then room temperature for 4 hours.			-육안 검사에 의한 상처가 없는 것, 녹, 얼룩 없는 것. 또는 변형이 없을 것. (No scar, rust, stain, or deformation by visual inspection.)

Part Number		Company	EVOWAVE	Approval No.	B0825R-0710
Specification	Φ8 x 2.5T	Name of applied Model	VG0825R10WXX	Enactment	2015.07.10
				Revision	

10. 신뢰성 시험 Reliability Test

NO	Item	Test Condition	Specification
10-7	열충격 시험 Thermal Shock Test	-40 °C와 85 °C, 각 30 분간 전체 200cycles로 구성한다. (1cycle = 1시간) Total 200cycles at -40°C and +85°C for 30min each (1cycle=1 H) -시료 변경시간 < 5분 Temperature Change Time < 5min -상온상습에서 4시간방치후 측정 Motor shall be measured after exposure at room temperature for 4 hours.	-정격 회전수 : 정격회전수 또는 초기치에 ±20% -Rated Load Speed: Initial value ±20%, or within rated load speed -정격전류: 초기치에 +20% -Rated Load Current: Initial value +20% -기타 The others: 7-6, 7- 7항의 조건에 따른다 (Conform to the section 7-6 and 7-7.) -육안 검사에 의한 상처가 없는 것, 녹, 얼룩 없는 것. 또는 변형이 없을 것. (No scar, rust, stain, or deformation by visual inspection.)
10-8	낙하시험 Drop Test	모터를 약 130g의 Dummy set에 고정된 상태 에서 150cm 높이에서 콘크리트에 6면 기준 각 면 10 회씩 총 60 회 자유 낙하 Dummy set (about 130g) motor shall be dropped Onto concrete plate. 10times each side of 6 directions from a height of 150 cm, total 60 times.	
10-9	내 진동시험 Vibration Test	모터를 표준 포장 상태에서 진동수 10Hz ~ 55Hz. 진폭 x, y, z 3 방향 각 2 시간, 총 6 시간 더한다. Standard-packed motor is subjected to sine wave 10Hz~55Hz. X, Y, Z directions for 2 hours each, total 6 hours.	

Part Number		Company	EVOWAVE	Approval No.	B0825R-0710
Specification	Φ8 x 2.5T	Name of applied Model	VG0825R10WXX	Enactment	2015.07.10
				Revision	

11. 구성도 Composition Draw

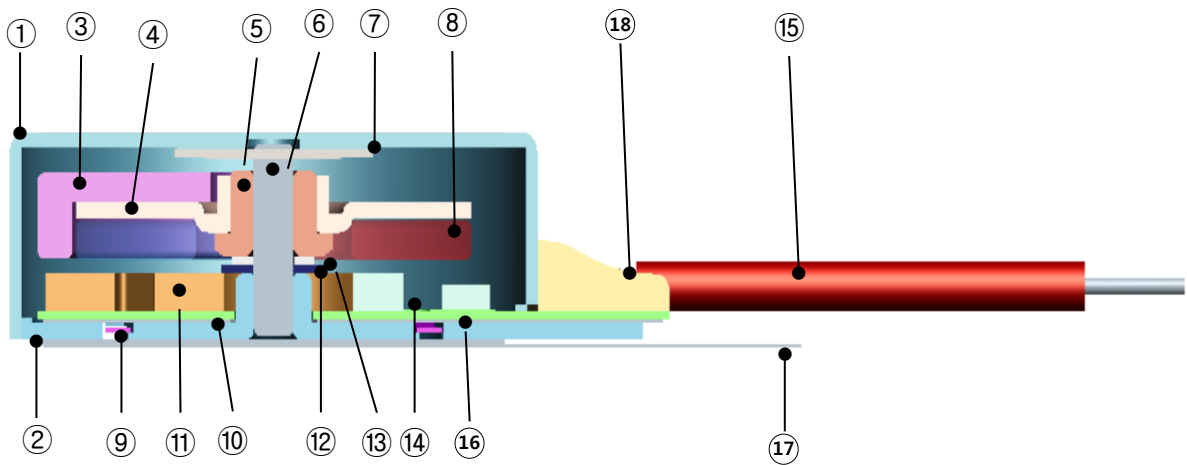

NO	PART	PART No.	MATERIAL	Q'TY	REMARKS
1	Case		SUS	1	
2	Bracket		인천동	1	
3	Weight		W-Ni	1	
4	Plate		SPC	1	
5	Metal Bearing		Cu	1	
6	Shaft		KWS4MA/DSR7	1	
7	Washer-Top		PET	1	
8	Magnet		Nd-Fe-B	1	
9	Cogging plate		SPC	1	
10	PCB		FPCB	1	
11	Coil Wire		Self Bonding Wire	0.15g	
12	Stopper Washer		PET	1	
13	Slide Washer		PEEK	1	
14	Driver IC			1	
15	Lead Wire		RED(+), BLUE(-)	1	
16	PCB Tape		TESA 4972	1	
17	Motor Tape		TEA4982	1	
18	Adhesive		LP163	0.01g	

Part Number		Company	EVOWAVE	Approval No.	B0825R-0710
Specification	Φ8 x 2.5T	Name of applied Model	VG0825R10WXX	Enactment	2015.07.10
				Revision	

12. 포장 Packing

12-1. 적용범위 Scope

이 포장 사양은 BLDC 진동 모터에 사용되는 VG0825R30WXX 적용된다.

This packing specification applies to the VG0825R30WXX, brushless type vibration motor.

12-2. 포장사양 Packing Specification

Item	Tray	Inner Box	Out Box
재질 Material	(PS) t=0.5mm	DW-1(Carton box)	DW-1(Carton box)
규격 Dimension	330(L) × 235(W) × 7(H)	350(L) × 250(W) × 150(H)	370(L) × 520(W) × 320(H)
수량 Quantity	100 ea MAX	2,000 ea MAX	8,000 ea MAX
중량 Weight	Approximately 140g	Approximately 2.9Kg	Approximately 13Kg

12-3. 포장도 Packing Drawing

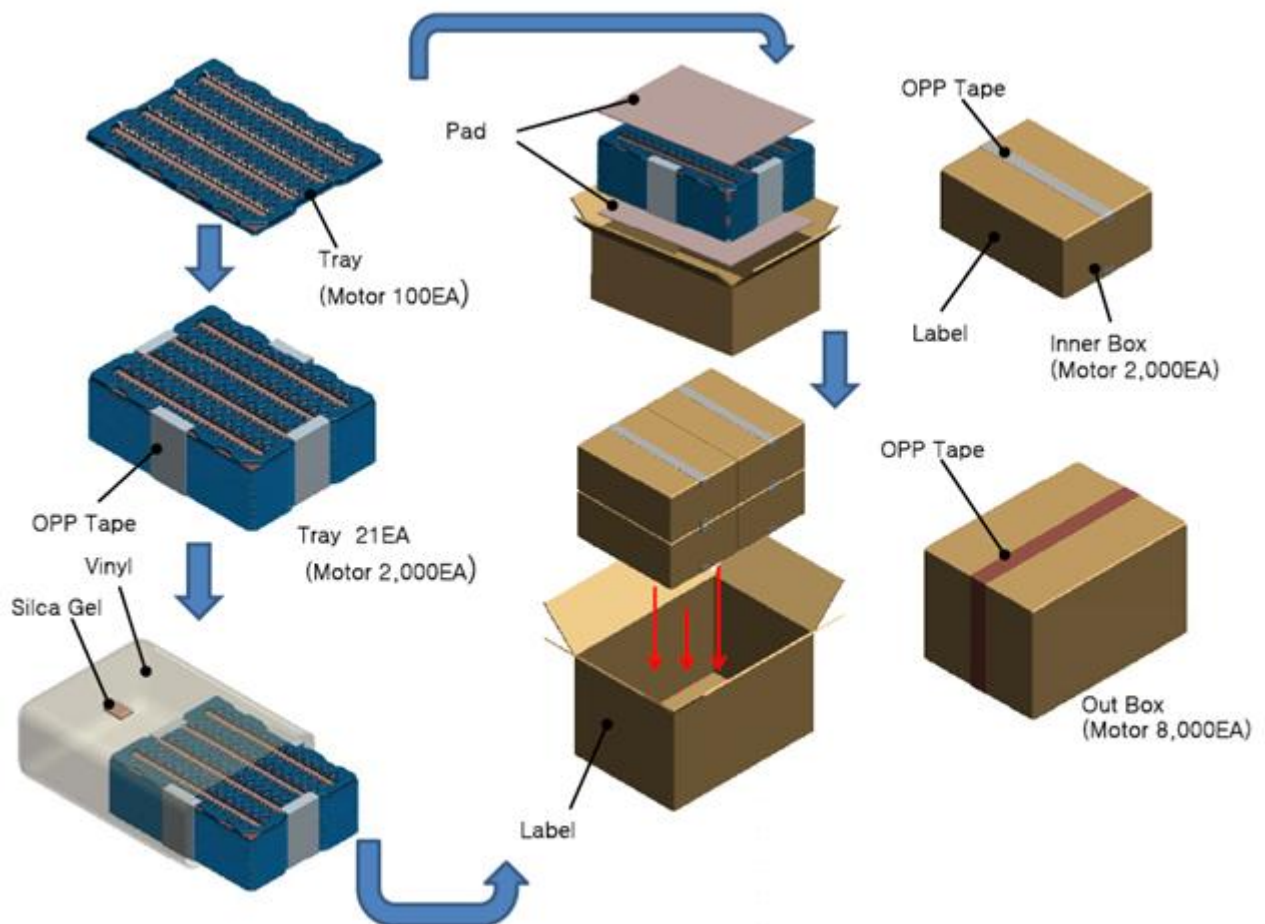

Part Number		Company	EVOWAVE	Approval No.	B0825R-0710
Specification	Φ8 x 2.5T	Name of applied Model	VG0825R10WXX	Enactment	2015.07.10
				Revision	

12-4. Tray포장 사양

12-4-1. Tray 사양

Item	Specification
재질 Material	(PS) t=0.75mm
규격 Dimension	330(L) × 235(W) × 7(H)
수량 Quantity	100 ea MAX
중량 Weight	Approximately 140g

12-4-2. Tray측면 단면도

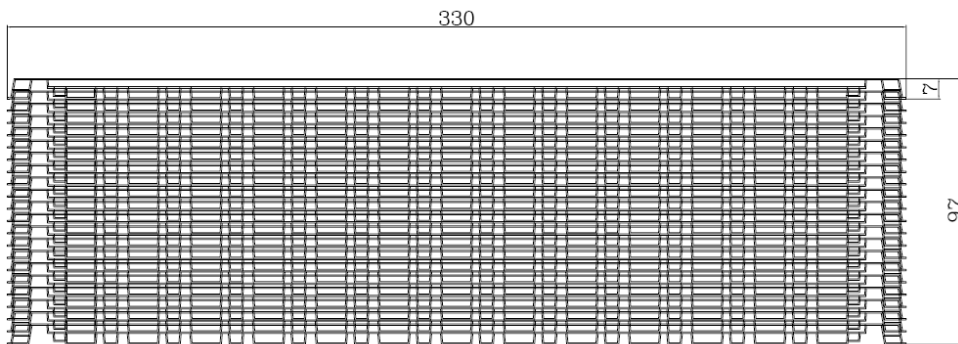

12-4-3. Tray상면

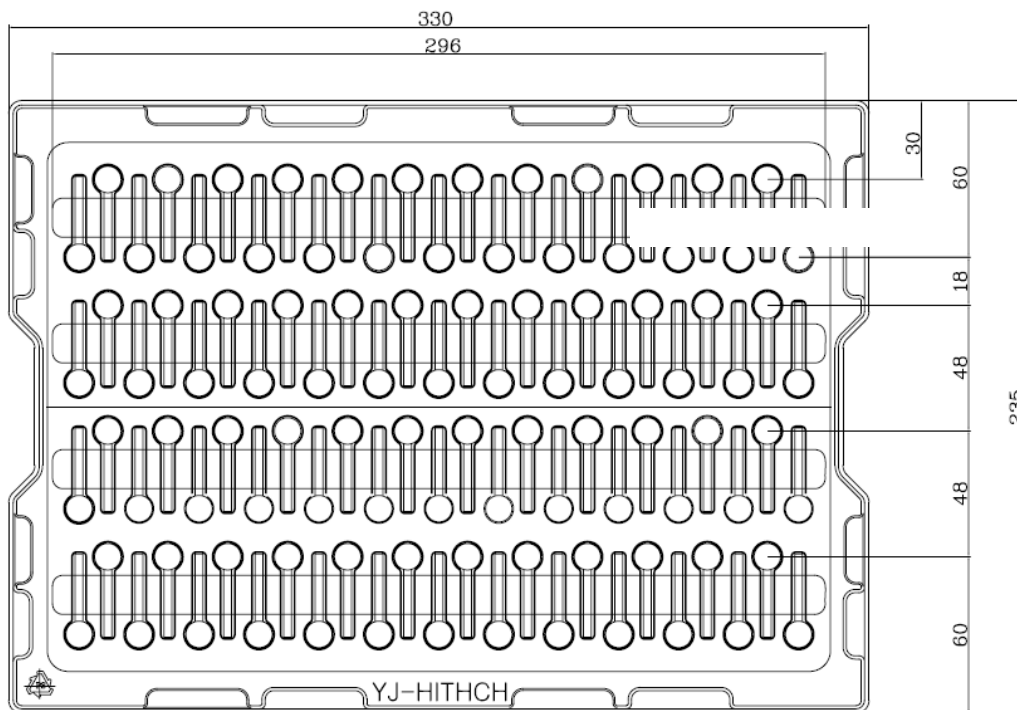

Part Number		Company	EVOWAVE	Approval No.	B0825R-0710
Specification	Φ8 x 2.5T	Name of applied Model	VG0825R10WXX	Enactment	2015.07.10
				Revision	

13. 주의사항Caution

NO	Item	Specification
13-1	사용범위 Operating Range	<p>-표준으로 동작상태 사용하지 않을 시 성능 및 제품의 수명에 문제가 될 수 있다.</p> <p>- When using on the operating condition different from a standard, a problem can be generated to the performance and the life of a product.</p>
13-2	보관 Storage	<p>- 고온, 다습 한 장소에 6 개월 이상 장기간 보관 또는 작동시킬 경우 모터 전기적 성능이 저하 될 우려가 있습니다.</p> <p>- Avoid from placing motor for long term of six months under environmental condition of high temperature or extreme humidity, or motor may be deteriorated.</p>
13-3	Motor취급 Motor Handling	<p>-제품을 취급 할 때, Case 부분을 이용하여 무리한 외력을 가하지 마십시오.</p> <p>To handle the motor, hold the case softly.</p> <p>-Motor의 영구 자석 근처에 전기 성질이 있는 물체의 접촉을 피하십시오.</p> <p>Do not bring a magnetized object or attracted object by the magnet of motor, or such object may deteriorate a performance of motor.</p> <p>- 검사 실수로 전원 단자 (+ / -)의 Short 때 Drive IC가 손상 될 수 있습니다. DRIVE IC 손상을 방지하기 위해 전원 단자 (+ / -) 사이에 2uF 이상의 콘덴서를 모터와 병렬로 연결하여 검사를 하는 것이 안전합니다.</p> <p>input short to the motor due to mis-operating, Drive IC of the motor inside can be damaged. To avoid this problem, please add capacitor of 2uF or more between the power lines in parallel with the motor.</p> <p>-Drive IC 보호를 위해 DC4.5V 이상 공급하지 마세요.</p> <p>Supplying voltage more than DC4.5V can make IC out of function.</p>
13-4	기타 Others	<p>- 그것은 규칙 문제 발생시 기준으로 사양을 하고, 영진 하이테크 (주) 사이의 합의에서 고객과로 구성되어 있습니다.</p> <p>It is made to a rule make specifications into a basis at the time of problem generating, and with a customer under deliberations between Young Jin Hi-Tech CO.,LTD.</p>

Part Number		Company	EVOWAVE	Approval No.	B0825R-0710
Specification	Φ8 x 2.5T	Name of applied Model	VG0825R10WXX	Enactment	2015.07.10
				Revision	

14. 사양변경 Specification Change

- 변경이 있는 경우에는 사전에 그 내용, 실시 로트 등의 필수 사항을 명기 한 후 변경 신청서를 제출 해야 한다.
- 변경 내역 관리가 필요 승인이 필요한 경우에는 사양서에 개정 기호를 표시한다.
- Even when there is any change to this specification, change application report which has the information of details
 - of the change, lot of product, and etc shall be presented to customer before that change being carried out.
 - And mutual discussion may be necessary before the change being carried out.
- Revision history shall be recorded on to the specification sheet when the change record and approval may be required.

15. 안전규격 Safety standard

- 해당 되지 않는다.
Not applicable

16. 고장율 Failure rate

- 해당 되지않는다
Not applicable

.

.

Part Number		Company	EVOWAVE	Approval No.	B0825R-0710
Specification	Φ8 x 2.5T	Name of applied Model	VG0825R10WXX	Enactment	2015.07.10
				Revision	

17. 도면 (Drawing)

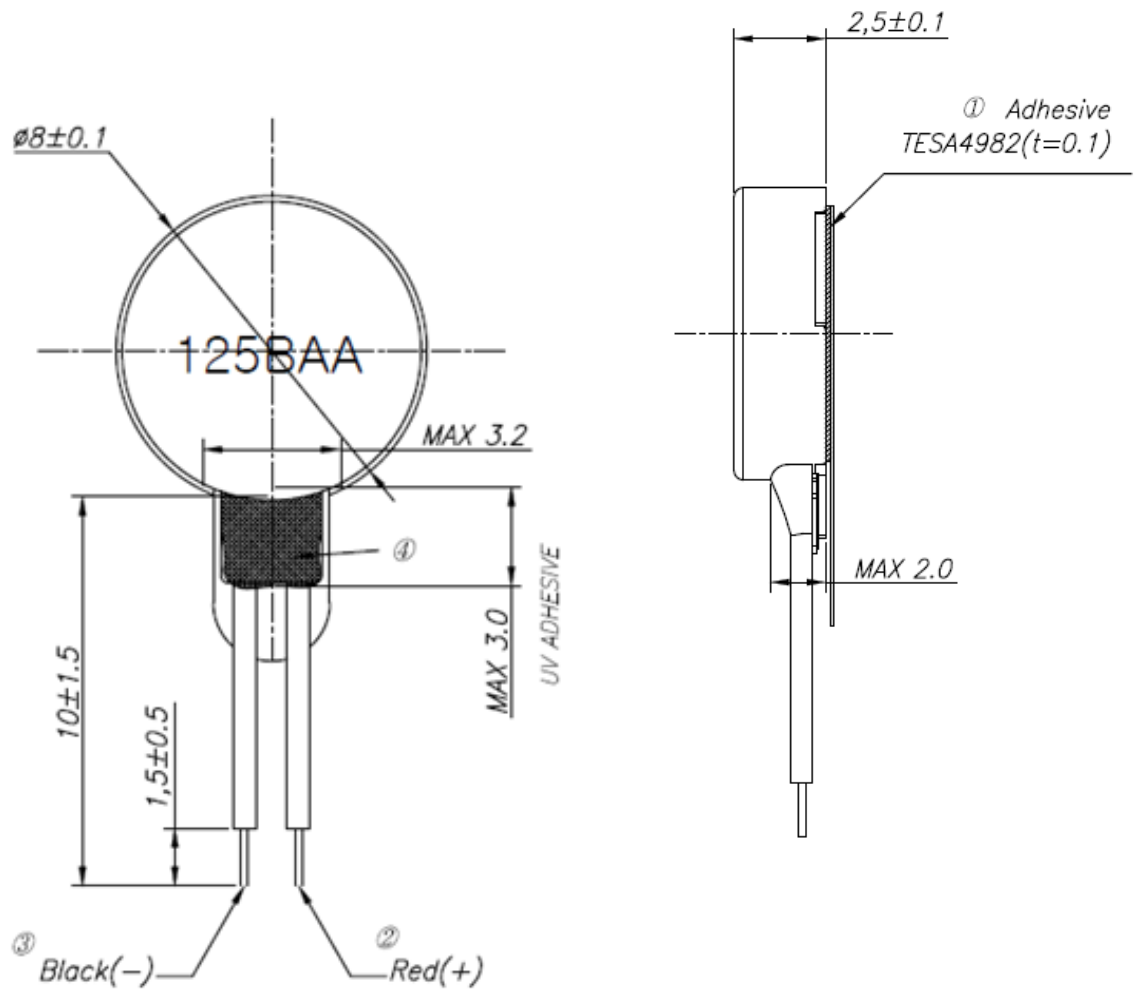
Direction : 1 \longrightarrow 6

Lot No : 1 2 5 B A A

1~2 : Date (1~31日)

3 : Month(10=A,11=B,12=C)

4 : Year(2010년: A~2020年: K)

5 : Product Line

6 : REV-Number

Part Number		Company	EVOWAVE	Approval No.	B0825R-0710
Specification	Φ8 x 2.5T	Name of applied Model	VG0825R10WXX	Enactment	2015.07.10
				Revision	